

A	B	C	D	A	B	C	D		
1	F45-1001	2368	665	1\5	9	F45-9001	1856	609	1\5
2	F45-1002	2368	665	1\5	10	F45-9008	510	845	2\5
3	F45-1007	2368	546	2\5	11	F45-9309	1856	845	2\5
4	F45-1008	2368	546	2\5	12	F45-9314	510	609	1\5
5	F45-2017	2103	666	3\5	13	g47\1	595	-	3\5
6	F45-2018	2103	666	3\5	14	g47\11	832	-	3\5
7	F45-3001	600	545	4\5	15	w106\9	2067	76	5\5
8	F45-3011	837	545	4\5	16	w107\9	2067	53	5\5

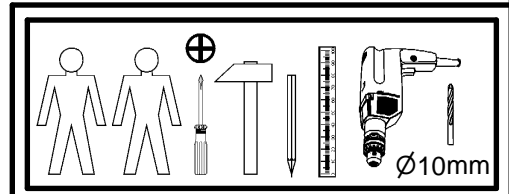

12x  d20	18x  d28	18x  Ø6x13 mm e3	12x  Ø6,3x10 mm e50	18x  Ø6,3x10 mm e51	24x  f1	2x  Ø10x50 mm f35	6x  g46	10x  32mm k75\3
44x  w107\9	2x  86x21x15\1,5 n14\2	2x  Ø5x60 mm p17	16x  Ø4x13 mm p28	4x  Ø3,5x16 mm p38	24x  Ø15x12 mm #16 r1	24x  20\11 r42	10x  Ø12xM10x17mm r66	1x  L-2067 mm w106\9
1x  2067 mm w107\9					24x  Ø12x4 mm s2	10x  Ø12x4 mm s41	1x  4 mm z15	1x  3 mm z22

1 §2

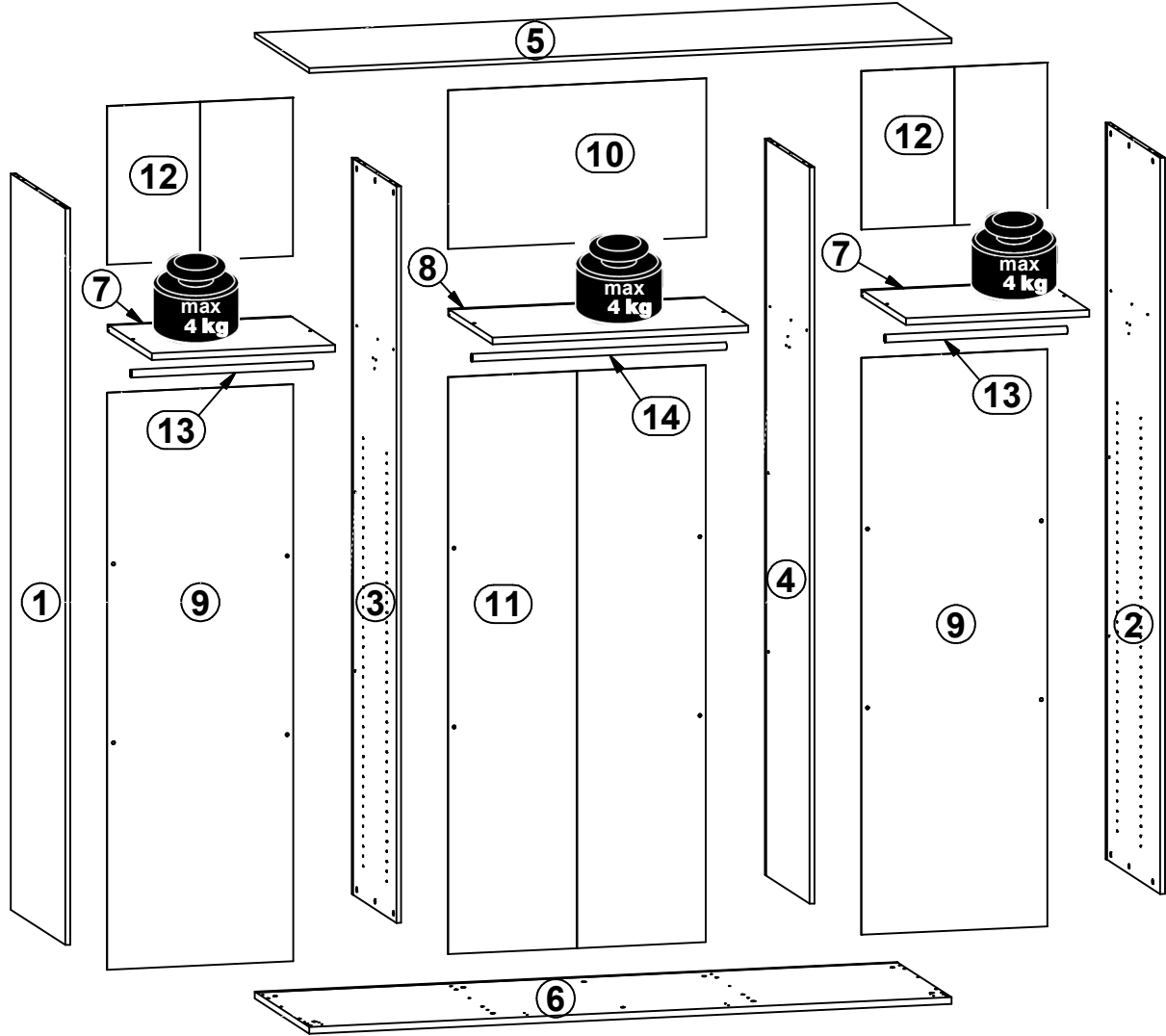
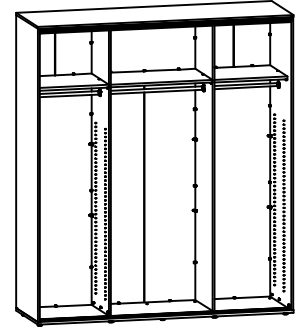
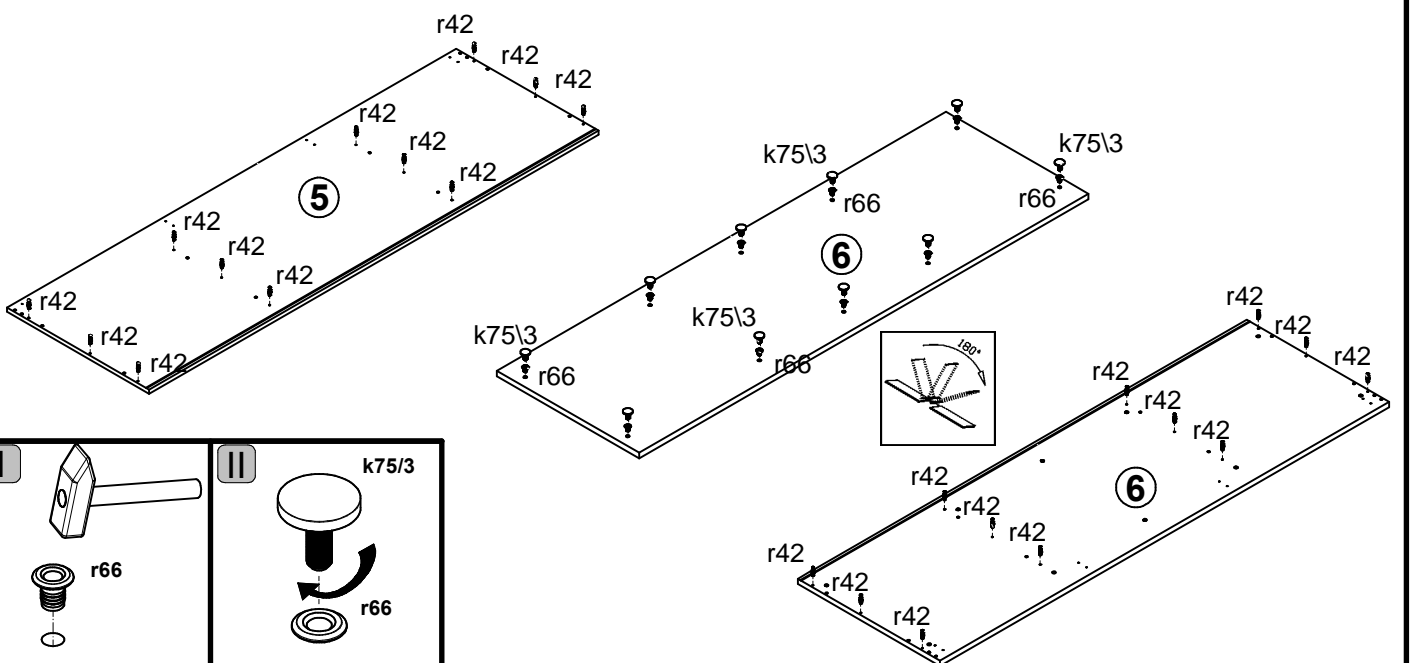
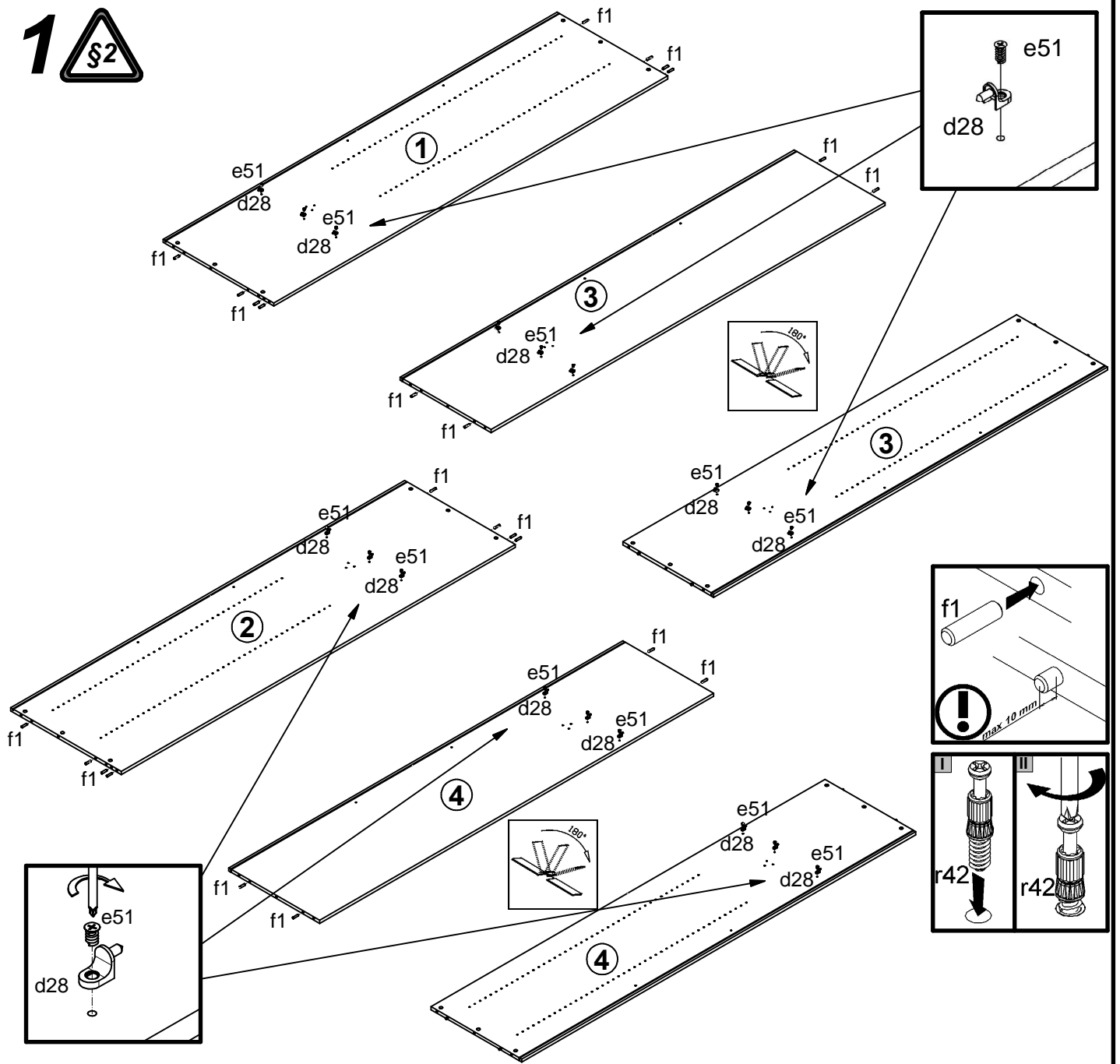

# 2

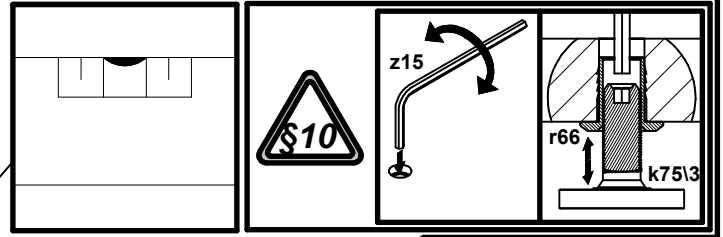
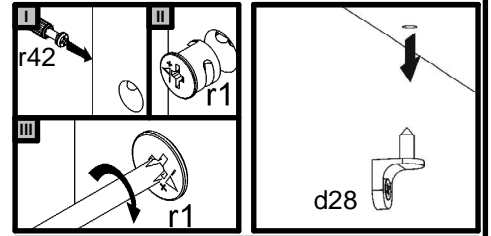
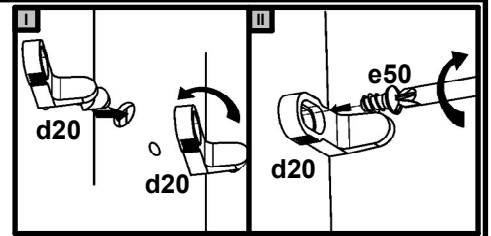
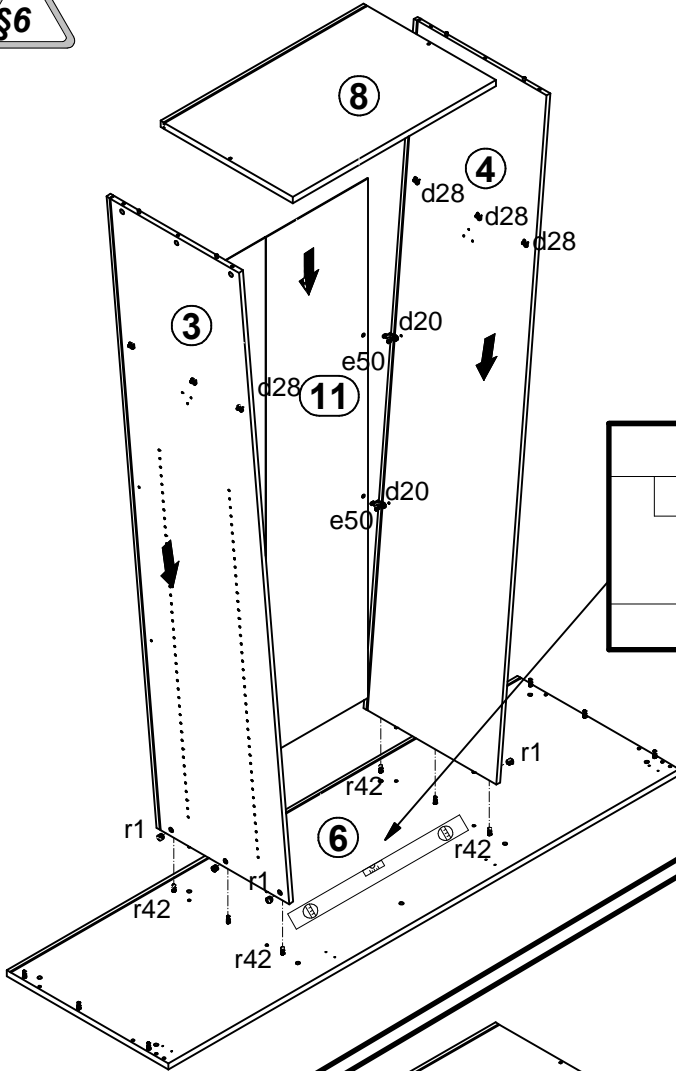

# 3

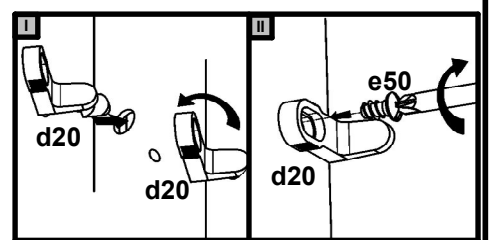
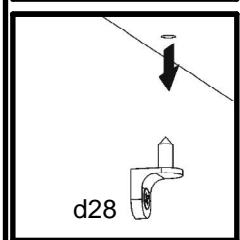
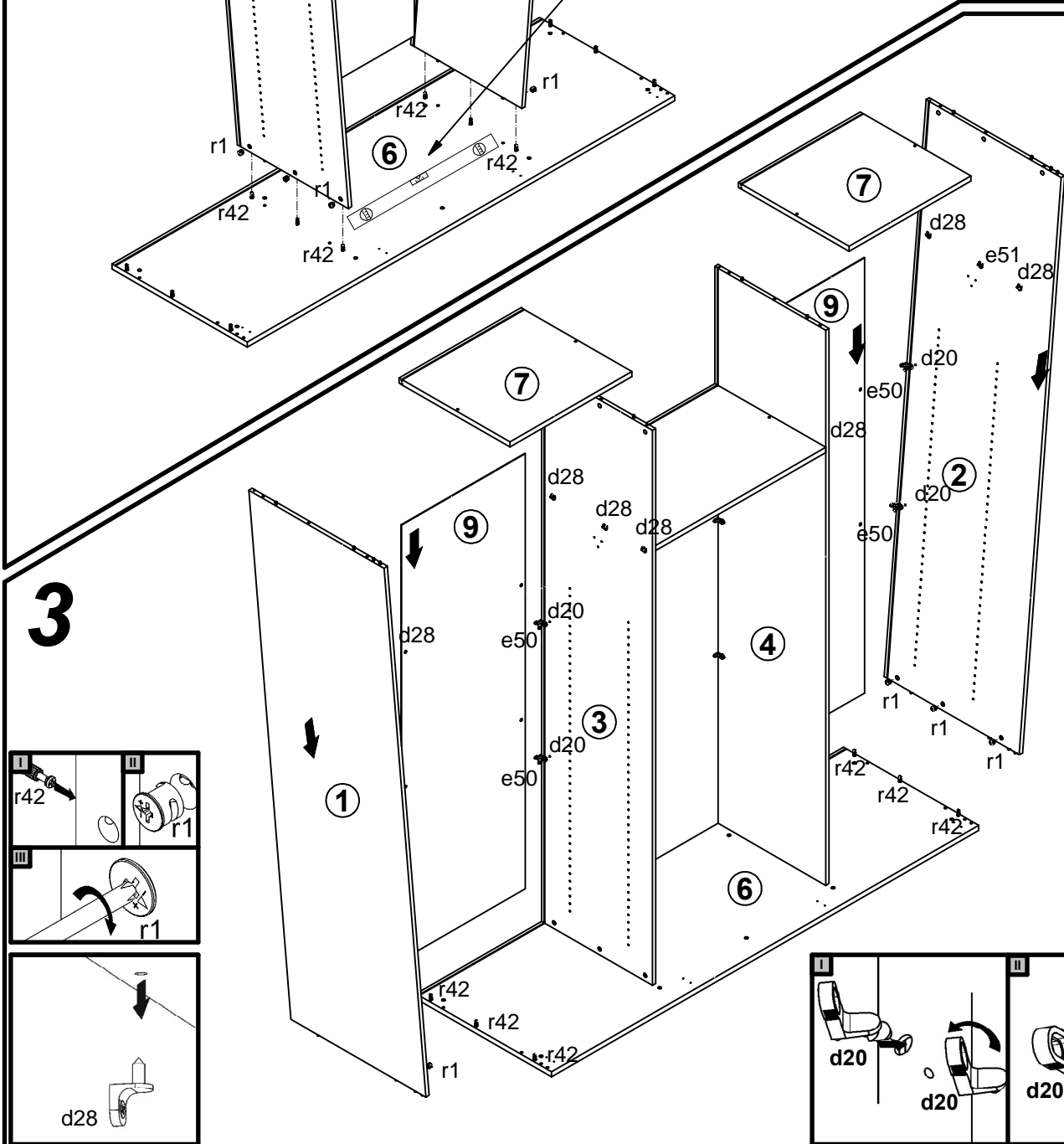

# 4

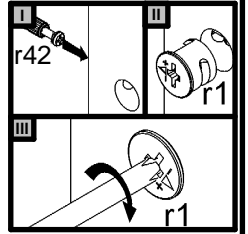
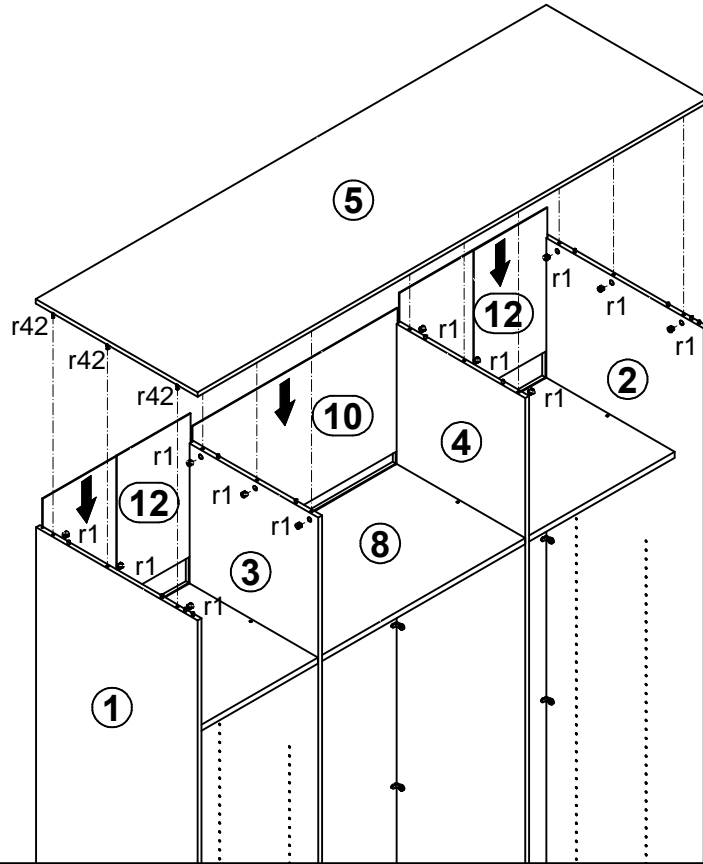

# 5

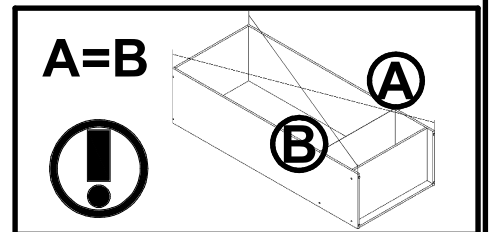
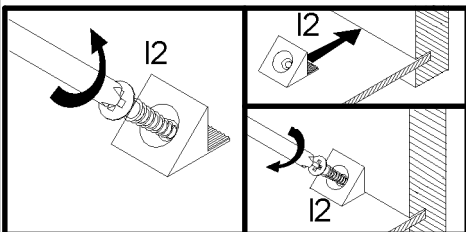
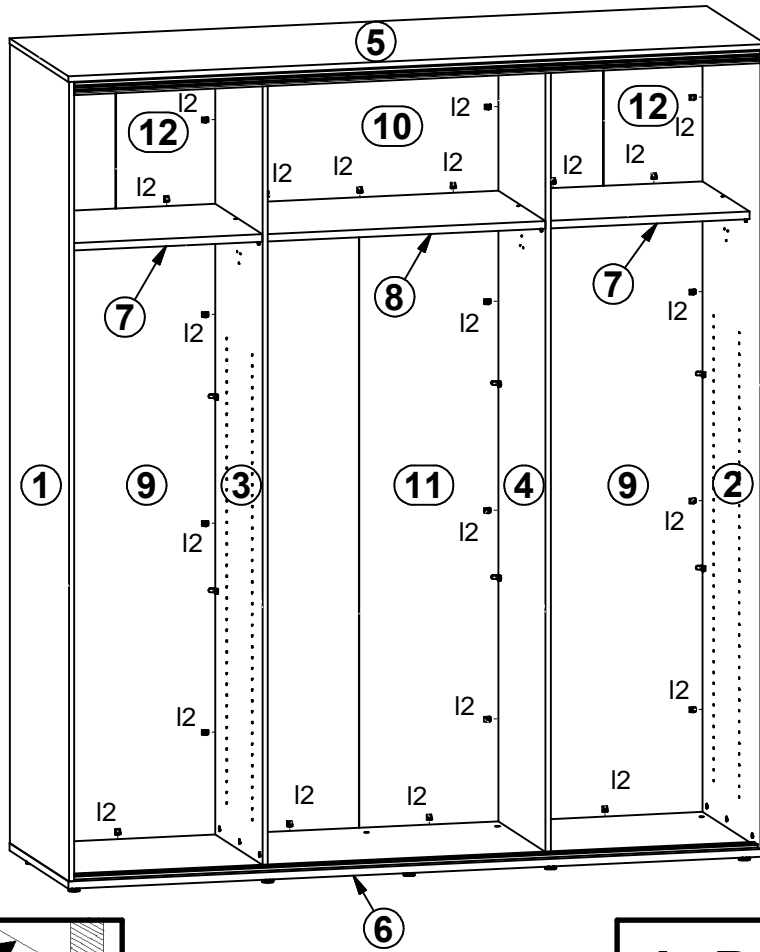

# 6

